

2PC FULL PORT 1000 WOG BALL VALVE, THREADED



DESIGN FEATURES:

- Steam rating: 150 psi WSP
- Blow-out-proof stem design
- ISO 5211 Mounting Pad
- Body: ASTM A351 Gr. CF8M
- Ball: SS316
- Stem: SS316
- Seat: Reinforced Teflon
- End Connections: Threaded End
- Working Pressure: 1000 psi
- Temperature Range: -50° to 450° F
- Options: Padlocking device
- TEST STANDARD: API 598
- Vacuum Service to 29" Hg
- NACE MR-0175 FULL COMPLIANCE
- Threaded Type:

MATERIALS LIST

NO.	PART NAME	MATERIAL	Q'TY
1	BODY	ASTM A351 Gr.CF8M	1
2	CAP	ASTM A351 Gr.CF8M	1
3	BALL	ASTM A351 Gr.CF8M	1
4	STEM	ASTM A276 Gr.316	1
5	SEAT	PTFE+15% G/F	2
6	GASKET	PTFE	1
7	THRUST WASHER	PTFE	1
8	PACKING	PTFE	1
9	GLAND	SS304	1
10	HANDLE	SS304	1
11	SPRING WASHER	SS304	1
12	HANDLE NUT	SS304	1
13	HANDLE SLEEVE	VINYL GRIP	1
14	LOCKING PLATE	SS304	1

ANSI B1.20.1 (NPT)
DIN 259/DIN 2999

ISO 228
BSP
PT

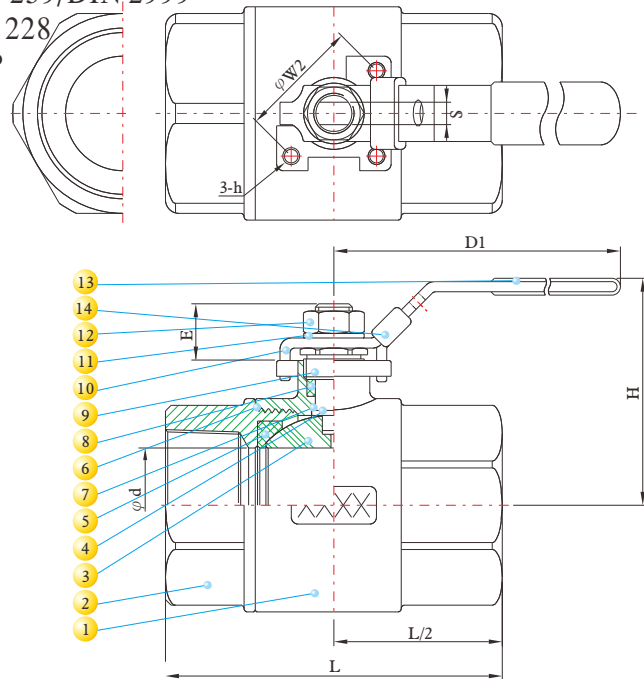

PRESSURE TEMPERATURE RATINGS

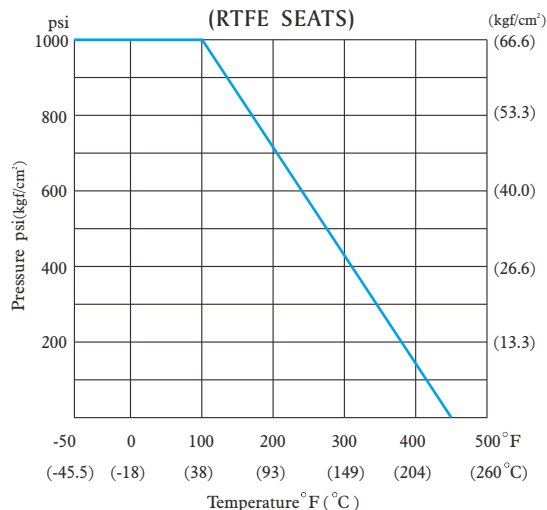

DIMENSIONS

SIZE	d		E		L		H		S		D1		W2		h (Option)	Cv Factor	Weight		
	inch	mm	inch	mm	inch	mm	inch	mm	inch	mm	inch	mm	inch	mm			Kg	Lb	
1/4"	8	0.43	11.0	0.61	15.5	2.34	59.5	2.11	53.5	0.21	5.45	4.06	103	1.42	36	M5*p0.8	16	0.35	0.77
3/8"	10	0.49	12.5	0.61	15.5	2.34	59.5	2.22	56.4	0.21	5.45	4.06	103	1.42	36	M5*p0.8	16	0.34	0.75
1/2"	15	0.59	15.0	0.57	14.5	2.50	63.5	2.17	55.0	0.21	5.45	4.06	103	1.42	36	M5*p0.8	26	0.36	0.79
3/4"	20	0.79	20.0	0.83	21.0	3.02	76.7	2.60	66.0	0.24	6.20	5.00	127	1.42	36	M5*p0.8	55	0.65	1.43
1"	25	0.98	25.0	0.77	19.5	3.56	90.5	2.80	71.0	0.24	6.20	5.00	127	1.42	36	M5*p0.8	110	0.93	2.05
1 1/4"	32	1.26	32.0	1.09	27.9	3.88	98.5	3.50	89.0	0.37	9.40	6.02	153	1.97	50	M6*p1.0	180	1.65	3.64
1 1/2"	40	1.50	38.0	1.50	27.5	4.65	118.0	3.62	92.0	0.37	9.40	6.02	153	1.97	50	M6*p1.0	270	2.26	4.98
2"	50	2.00	50.8	1.08	26.7	5.35	136.0	4.21	107.0	0.37	9.40	7.60	193	1.97	50	M6*p1.0	500	3.62	7.97
2 1/2"	65	2.56	65.0	1.02	26.0	6.48	164.5	4.69	119.0	0.37	9.40	7.60	193	2.76	70	M8*p1.25	800	6.14	13.53
3"	80	3.15	80.0	1.50	38.0	7.62	193.5	5.16	131.0	0.47	12.00	10.98	279	4.02	102	M10*p1.5	1150	11.15	24.56
4"	100	3.94	100.0	1.89	48.0	8.50	216.0	6.73	171.0	0.47	16.00	13.19	335	4.02	102	M10*p1.5	2120	19.00	41.89

