

TC-02XWS VALVE

2PC FULL PORT 1000 WOG SEAL WELDED BALL VALVE, THREADED



DESIGN FEATURES:

- Steam rating: 150 psi WSP
- Blow-out-proof stem design
- Temperature Range: -50° F to 450° F
- Options: locking device
- TEST STANDARD: API 598
- Vacuum Service to 29" Hg
- NACE MR-0175 FULL COMPLIANCE
- MSS SP-110 Compliant
- Threaded Type:

ANSI B1.20.1 (NPT)

DIN 259/DIN 2999

ISO 228

BSP

PT

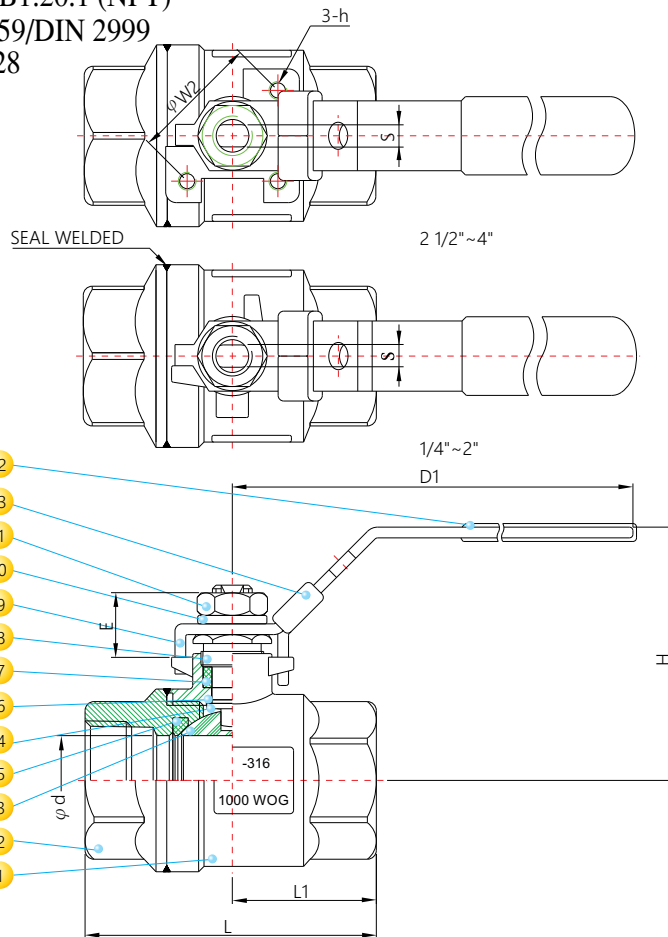

MATERIALS LIST

NO.	PART NAME	MATERIAL	Q'TY
1	BODY	ASTM A351 Gr.CF8M	1
2	CAP	ASTM A351 Gr.CF8M	1
3	BALL	ASTM A351 Gr.CF8M	1
4	STEM	ASTM A276 Gr.316	1
5	SEAT	PTFE+15% G/F	2
6	THRUST WASHER	PTFE	1
7	PACKING	PTFE	1
8	GLAND	SS304	1
9	HANDLE	SS304	1
10	SPRING WASHER	SS304	1
11	HANDLE NUT	SS304	1
12	HANDLE SLEEVE	VINYL GRIP	1
13	LOCKING PLATE	SS304	1

PRESSURE TEMPERATURE RATINGS

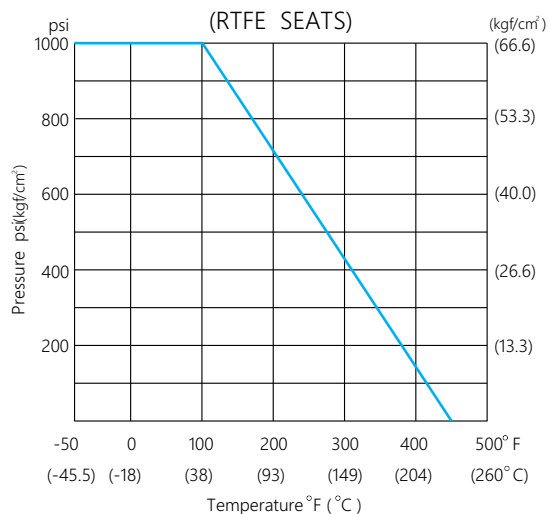

DIMENSIONS

SIZE	d	E	L	L1	H	S	D1	W2	h	Cv	Weight										
inch	mm	inch	mm	inch	mm	inch	mm	inch	mm	Factor	Kg	Lb									
1/4"	8	0.43	11.0	0.61	15.5	2.28	57.8	1.13	28.8	2.25	57.2	0.21	5.45	4.06	103	16	0.26	0.57			
3/8"	10	0.49	12.5	0.61	15.5	2.28	57.8	1.13	28.8	2.25	57.2	0.21	5.45	4.06	103	16	0.24	0.53			
1/2"	15	0.59	15.0	0.57	14.5	2.43	61.7	1.21	30.7	2.33	59.1	0.21	5.45	4.06	103	26	0.30	0.66			
3/4"	20	0.79	20.0	0.83	21.0	2.76	70.1	1.38	35.0	2.46	62.6	0.21	5.45	4.06	103	55	0.42	0.93			
1"	25	0.98	25.0	0.77	19.5	3.20	81.3	1.58	40.2	2.78	70.7	0.24	6.20	5.00	127	110	0.70	1.54			
1 1/4"	32	1.26	32.0	1.09	27.9	3.78	96.0	1.86	47.2	3.00	76.2	0.24	6.20	5.00	127	180	1.10	2.42			
1 1/2"	40	1.50	38.0	1.50	27.5	4.43	112.5	2.19	55.6	3.51	89.1	0.37	9.40	6.02	153	270	1.86	4.10			
2"	50	2.00	50.8	1.08	26.7	4.96	126.0	2.46	62.4	3.87	98.2	0.37	9.40	7.60	193	500	2.85	6.28			
2 1/2"	65	2.56	65.0	1.02	26.0	6.63	168.5	3.35	85.0	4.35	110.6	0.37	9.40	7.60	193	2.76	70	M8*P1.25	800	6.25	13.77
3"	80	3.15	80.0	1.50	38.0	7.54	191.4	3.78	95.9	4.88	124.0	0.47	12.00	10.98	279	4.02	102	M10*P1.5	1150	10.42	22.95
4"	100	3.94	100.0	1.89	48.0	8.52	216.5	4.26	108.3	6.63	168.5	0.47	16.00	13.19	335	4.02	102	M10*P1.5	2120	17.20	37.89

